

TRANSPORT TANK DEFENCE



TRANSPORT TANK DEFENCE

Together with the Swedish FMV this IBC has been meticulously designed and built to fulfil any requirement that may occur in the field. Thanks to its stainless-steel inner tank our TTD is extremely long-lasting no matter what fuel you require; Diesel, Petrol, Kerosene, JetA1, or HVO, this tank is built for them all.

Our Transport Tank Defence is perfect for:

- Defence
- Construction sites
- Backup Power/Energy reserves
- Emergency Management
- Municipalities

Certifications & approvals

- The product is approved and certified as IBC container (Intermediate Bulk Container) in accordance with the following regulations and recommendations:
 - UN** (UN's recommendations for transport of diesel etc.)
 - ADR** (European regulations for international road transport of diesel etc.)
 - RID** (international regulations for rail transport of diesel etc.)
 - IMDG** (code for international maritime transport of diesel etc.)
 - PEFC** (PEFC is a system for sustainable forestry certification)

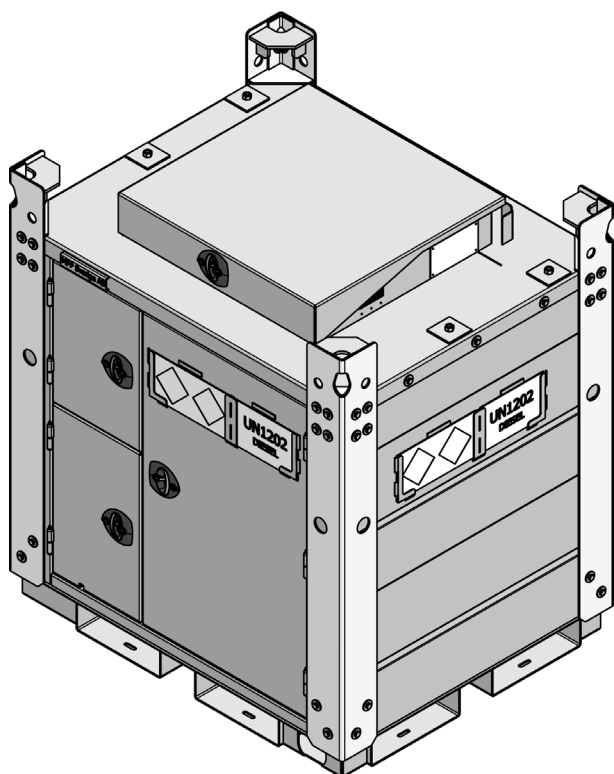

About MPP

MPP is a family-owned company in Fjärås in Western Sweden, and has been operating in the Scandinavian market since 2004. We manufacture approved mobile diesel tanks, fuel stations and stationary fuel tanks that are developed for the Nordic climate. We mainly work with companies involved in rental, construction, haulage, forestry and agriculture which, like us, have high standards in terms of quality, safety and the environment.

MPP is a committed partner whose products – from mobile fuel tanks to complete fuel stations – are safe and easy to use. Our brand promise is: **Fuel management in a safe and convenient way**

Tank specifications

Art. no:	101289	101291
Description:	TT Defence 1000 liter	TT Defence 3000 liter
Model description:	TTD100	TTD300
Storage number:	M7074-609011	M7074-609111
Volume 95% (l):	990	2780
Length (mm):	1477	1477
Width (mm):	1207	2292
Height (mm):	1630	1630
Net weight (kg):	978	1449

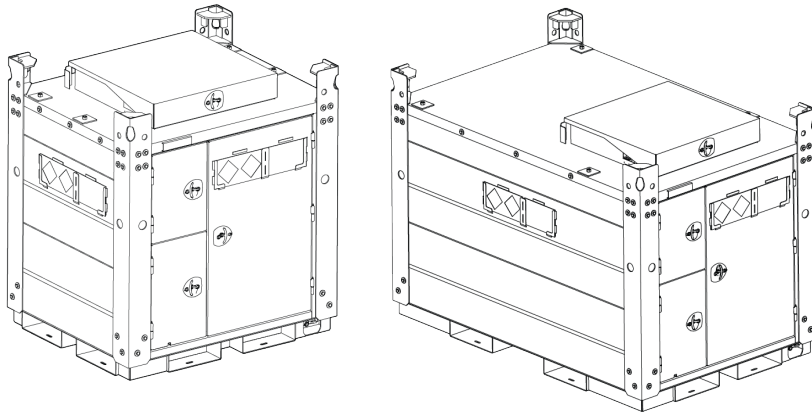

Tank Equipment Cabinet

In the tank's equipment cabinet, you will find:

- 24v and 230v power inlet for pump and light.
- 40l/min handpump for when no power is available
- 24v Fillrite Pump 75L/min
- Water drainage pump
- Junction box with switches
- Space for oil drums
- Fire extinguisher
- Tools
- Fold out 10m hose reel with automatic pistol
- Suction and return for running 3 generators simultaneously
- 3" fuelling connection Stanag 3756
- All equipment Atex-approved
- Filter & Flowmeter
- Lifting Chains

The cabinet doors are equipped with rubber seals to prevent dust and dirt from entering and have built-in locks that can be padlocked.

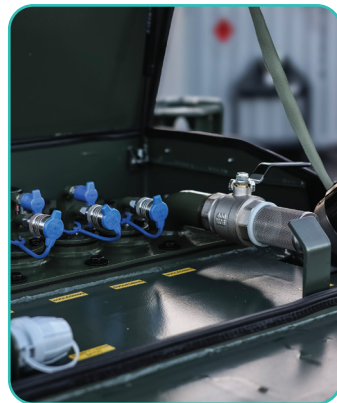
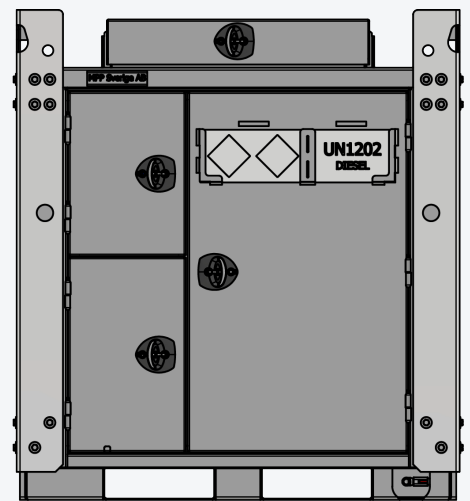

Do not hesitate to contact us!

We will be happy to assist you with any questions you may have.



Sweden Roy Vilhelmsson +46(0)300-521936 roy@mpp.se
Europe Kylan Mitchell +46(0)300-521938 kylan@mpp.se



MPP Sverige AB Fjärås Industriväg 17
 439 74 Fjärås, Sverige
 +46 300-521 930
 www.mpp.se