

TTC Fuel Farm



Customized filling stations

The TTC Fuel Farm can be adapted to fill different fuels, such as HVO, Diesel, Petrol and AdBlue. The tanks can also be connected to form a larger tank for fueling various units.

The model shown has TTC 3+3+3+2m3 tanks installed on a 6-meter flat horizontal frame, giving it a total volume of 11,000 liters.

TTC Fuel Farm is adapted for:

- Construction sites
- Rental
- Electricity & Reserve Power
- Emergency Management
- Municipalities
- Land & Facilities and Building Heating.

Certifications & approvals

- The product is approved and certified as IBC container (Intermediate Bulk Container) in accordance with the following regulations and recommendations:

UN (UN's recommendations for transport of diesel etc.)

ADR (European regulations for international road transport of diesel etc.)

RID (international regulations for rail transport of diesel etc.)

IMDG (code for international maritime transport of diesel etc.)

PEFC (PEFC is a system for sustainable forestry certification)



About MPP

MPP is a family-owned company in Fjärås in Western Sweden, and has been operating in the Scandinavian market since 2004. We manufacture approved mobile diesel tanks, fuel stations and stationary fuel tanks that are developed for the Nordic climate. We mainly work with companies involved in rental, construction, haulage, forestry and agriculture which, like us, have high standards in terms of quality, safety and the environment.

MPP is a committed partner whose products – from mobile fuel tanks to complete fuel stations – are safe and easy to use. Our brand promise is: **Fuel management in a safe and convenient way**

Customizable and secure concept

When a customer requests more tanks or larger volumes, MPP will modify the installation to meet their demands.

On the load changer frame, special fasteners are designed to allow for the quick securing of tanks with existing hole patterns.

Adaptable to fill different fuels

The TTC Fuel Farm can be adapted to fill different fuels, such as HVO, Diesel, Petrol and AdBlue. The tanks can also be connected to form a larger tank for fueling various units.

Communication between tanks and terminals

To ensure a longer operation, the tanks can be linked with our power supply packages for electric and reserve power units. Quick couplings are used to connect the units for a quick start-up and to disconnect for proper transport in accordance with ADR regulations.

Example installations

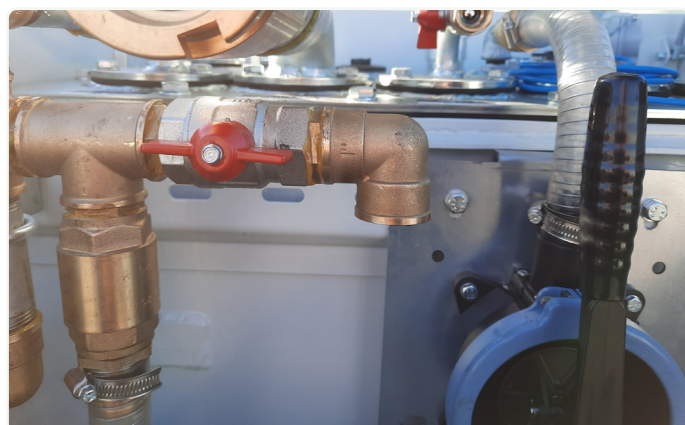
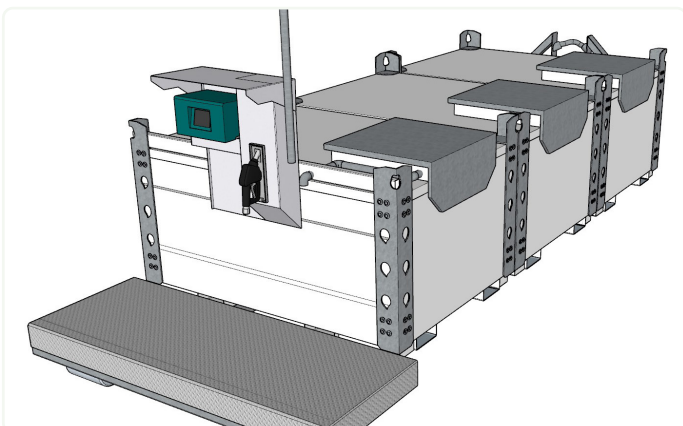

MPP Sverige AB Fjärås Industriväg 17
439 74 Fjärås, Sverige
+46 300-521 930
www.mpp.se

Do not hesitate to contact us!

We will be happy to assist you with any questions you may have.

